

# High resolution UV, Alpha and Neutron Imaging with the Timepix CMOS readout

*J. Vallergera, J. McPhate, A. Tremsin and O. Siegmund*  
*Space Sciences Laboratory*  
*University of California, Berkeley*



# Desire for better detector spatial resolution

- Optics cannot always solve problem
  - Limits on physical size of detector is often fixed  
e.g. Space-based imaging (mass, optical focal length)
  - Projection length where optics don't work
- Make pixels smaller rather than detector bigger
- Ultimate limit is size of interaction region of radiation of interest



# Imaging, Microchannel Plate Detectors

~~Photocathode converts photon to electron~~  
~~MCP~~ ~~neutron~~ ~~electron~~ ~~alpha~~

MCP(s) amplify electron by  $10^4$  to  $10^8$

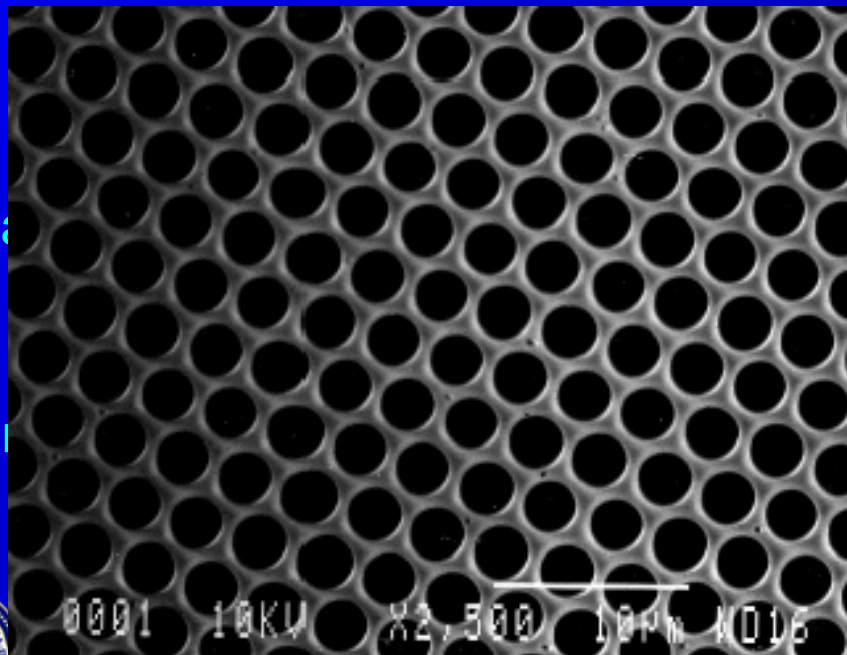
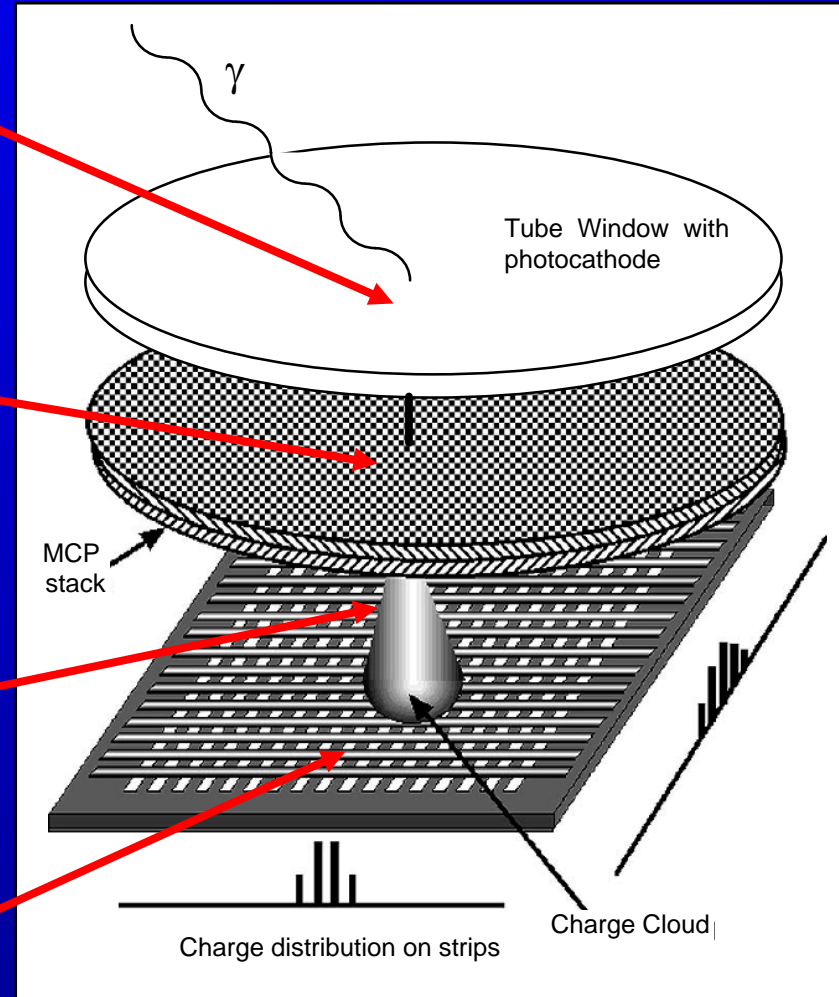

# Medipix/Timepix ASIC readout

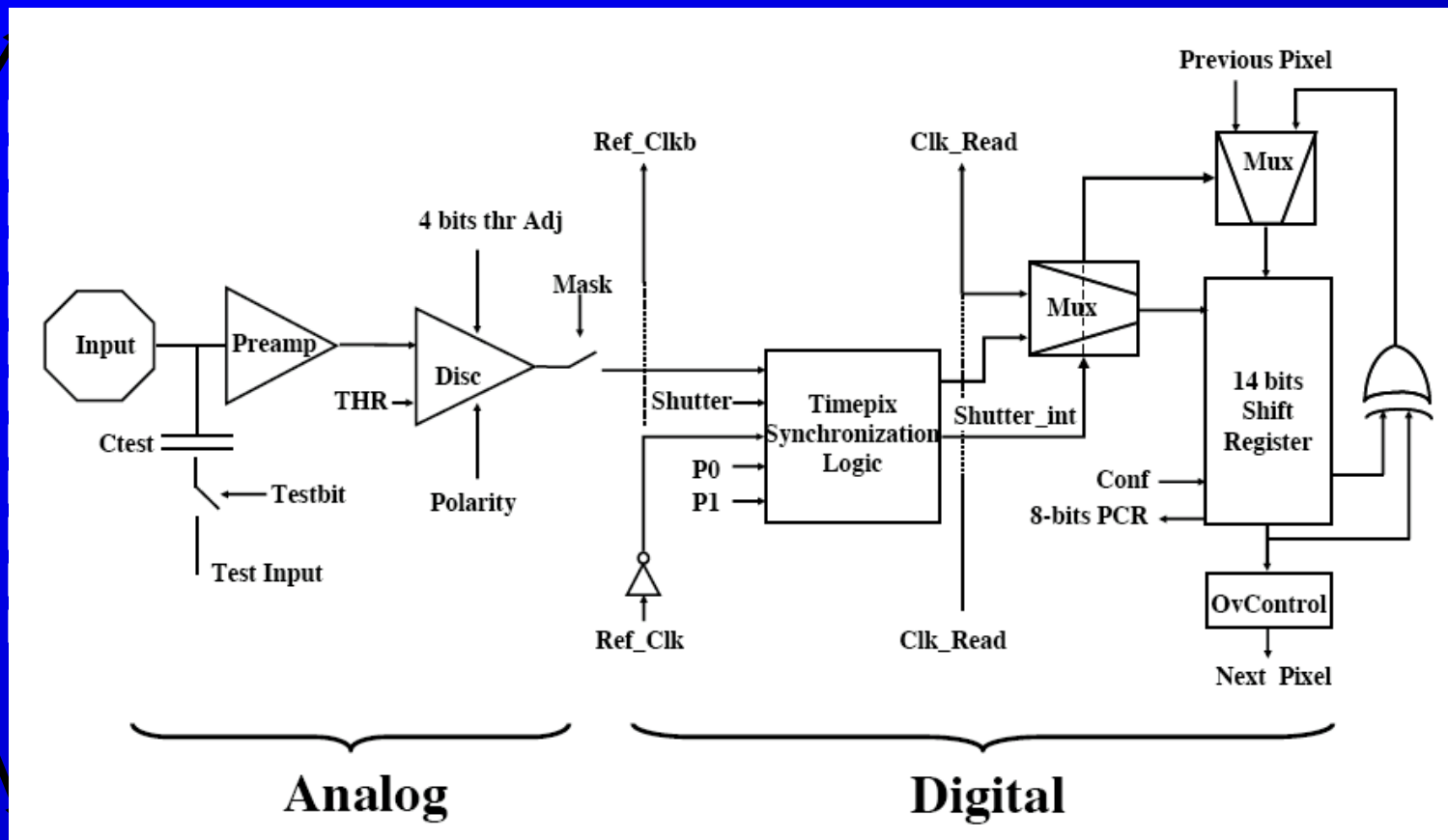
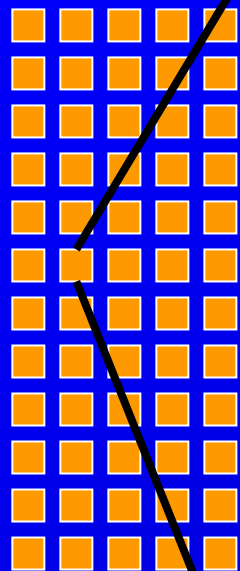

# “Time over Threshold” = ADC

Clock

Thresh.

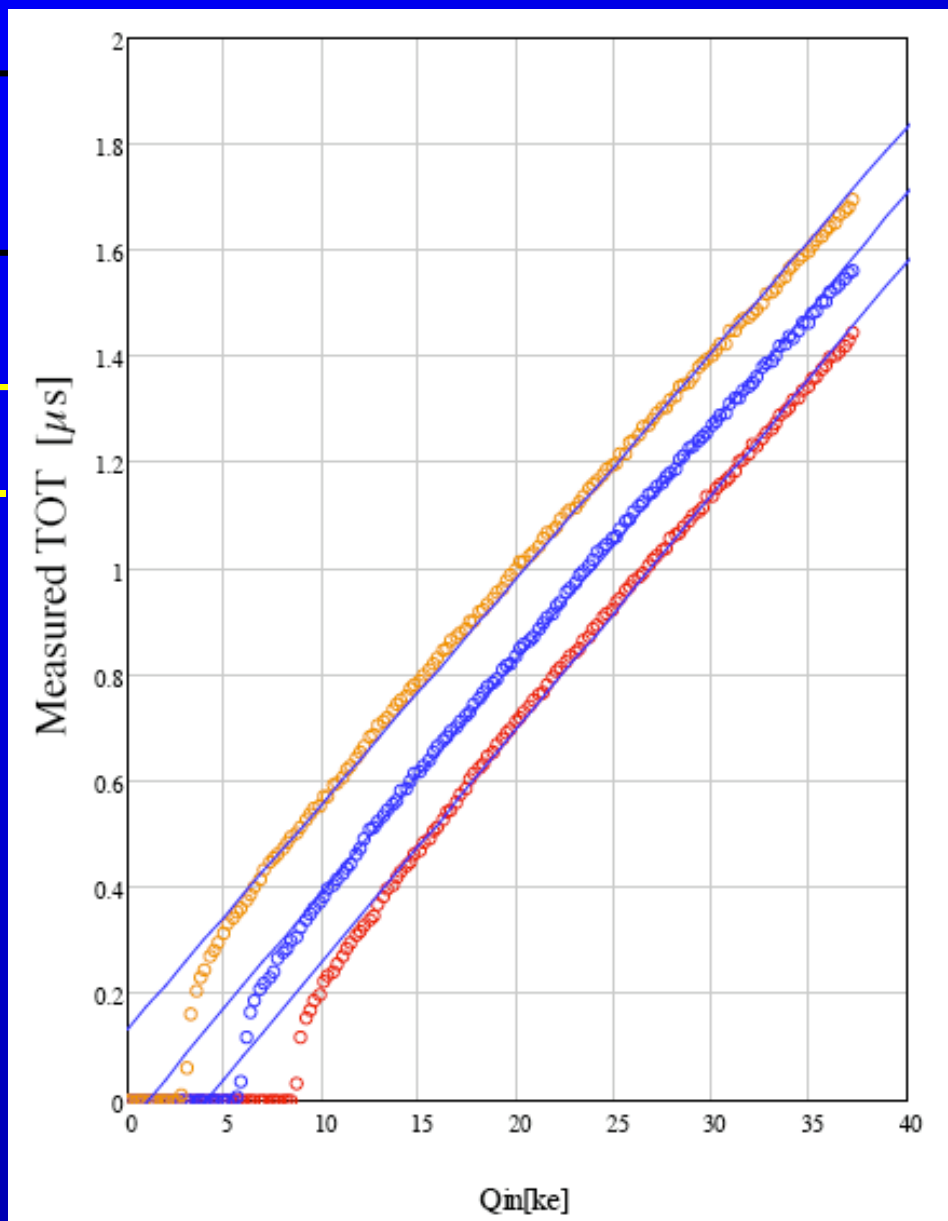

# Timepix version of Medipix



Amplitude rather than counts  
using “time over threshold”  
technique

If charge clouds are large, can  
determine centroid to sub-  
pixel accuracy

Tradeoff is count *rate* as event  
collisions in frame can  
destroy centroid information

Single UV photon events



# Centroiding Algorithm

For each Frame

- Find local event peaks in 3x3 “boxcar” smoothed image

For each event

- Calculate simple 5x5 “center of gravity”
- Threshold on event sum and size
- Apply distortion correction
- Histogram *centroids* into high resolution 2D image

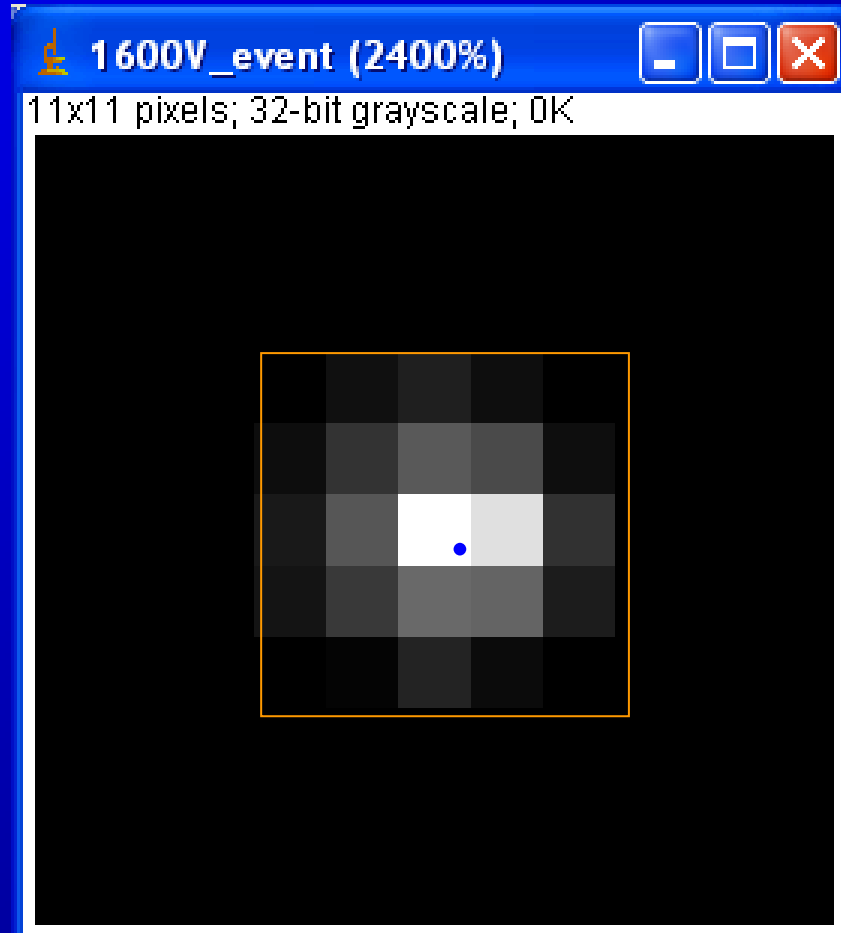

# Original Medipix mode readout



256 x 256  
(14 mm)

UV image limited by  $55 \mu\text{m}$  pixel



# Zoomed UV image of pattern in Medipix mode

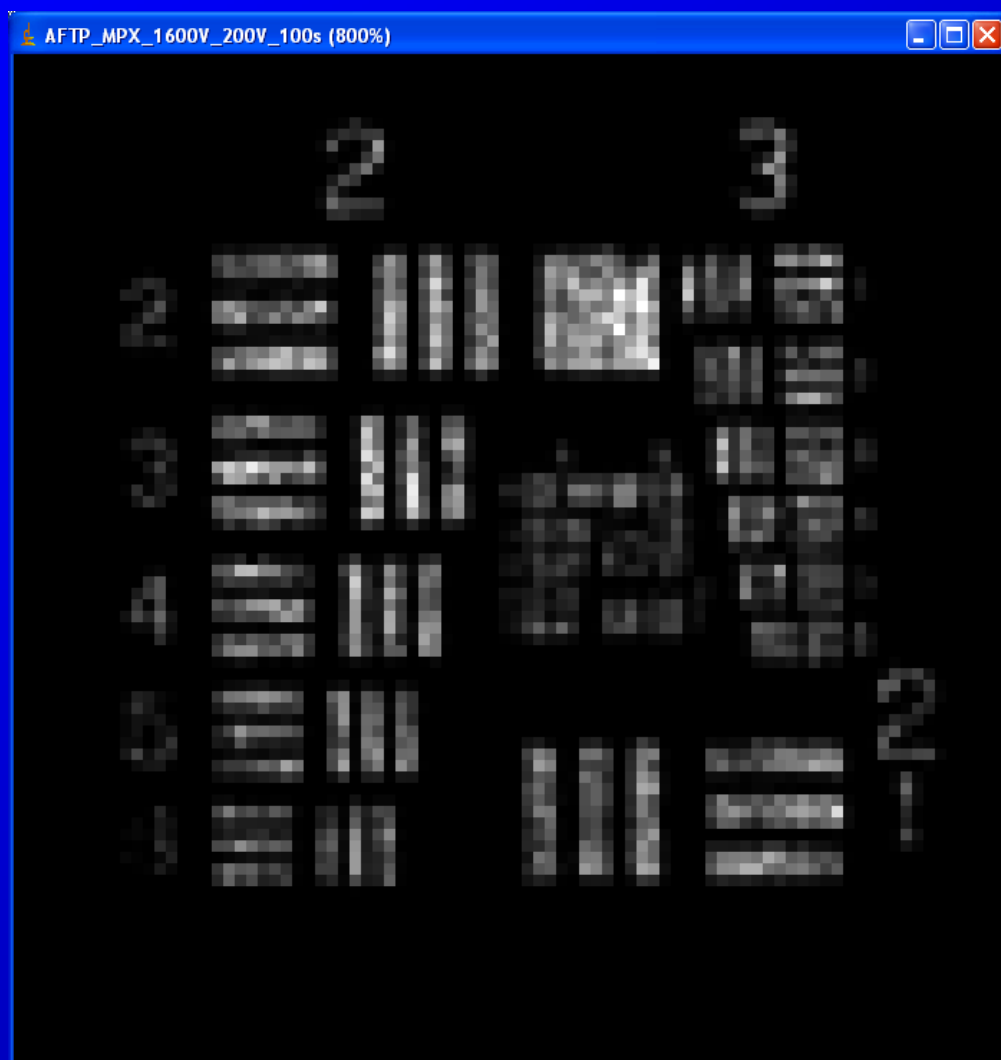

Pattern 3-2 (= 9 lp/mm) barely resolved

# Timepix centroided mode

## Factor of 8 improved resolution!

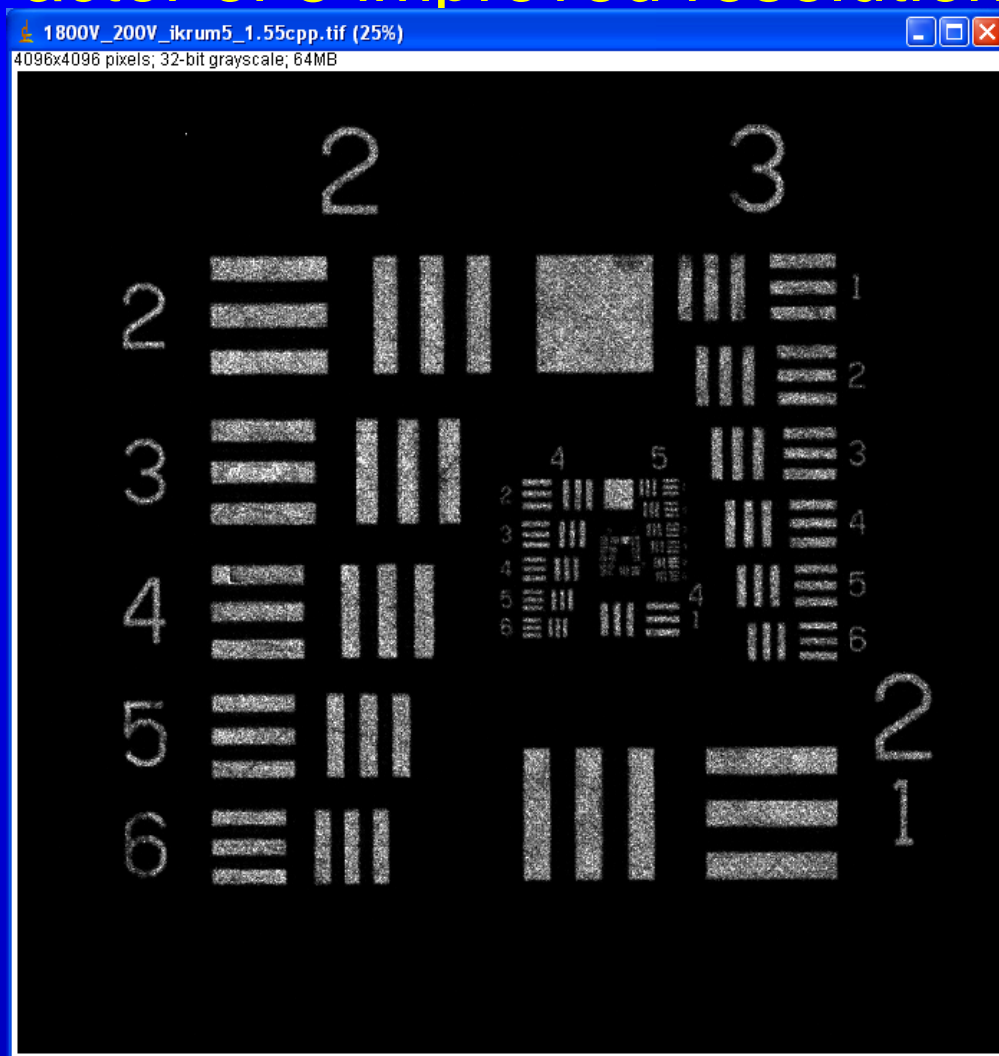

256 x 256 converted to 8192x8192 pixels (1.7 $\mu$ m pixels)



# Current Implementation

- Installed as a plugin in Pixelman software
- Designed to be computationally fast for later use in FPGA at kHz frame rates
- 30-60 events per frame
- Muros board at ~20 frames/sec
- 50k to 200k frames into 1 image (4096x4096, 1.7 $\mu$ m pixels)



# Zoomed

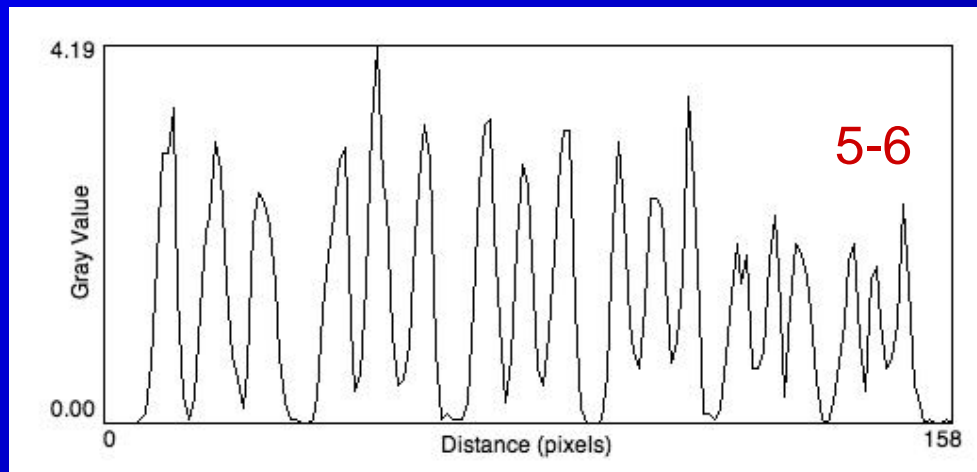
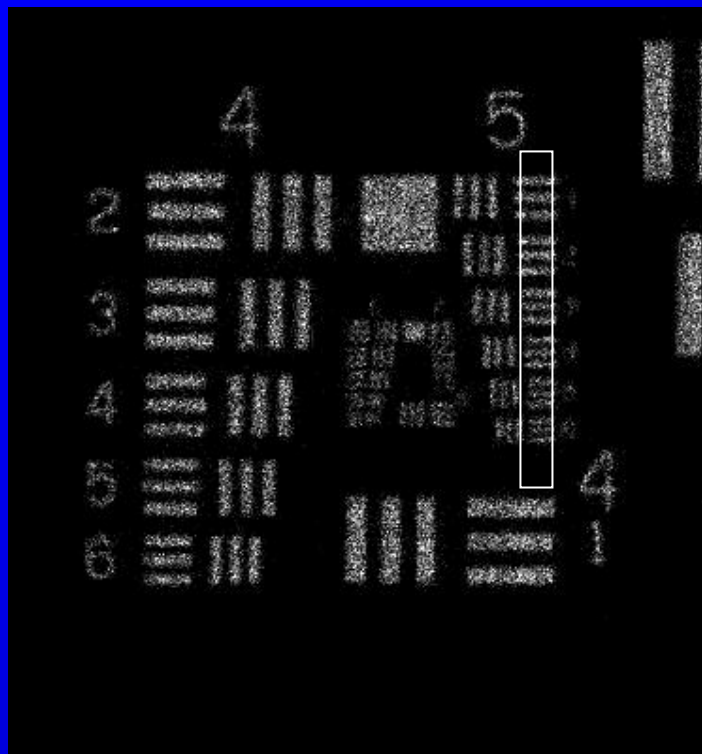

5-6 pattern resolved = 57 lp/mm  
Linewidth = 8.8  $\mu\text{m}$

The MCP pore spacing of 8 $\mu\text{m}$  limits further improvement



# MCP pores (10 on 12 micron)

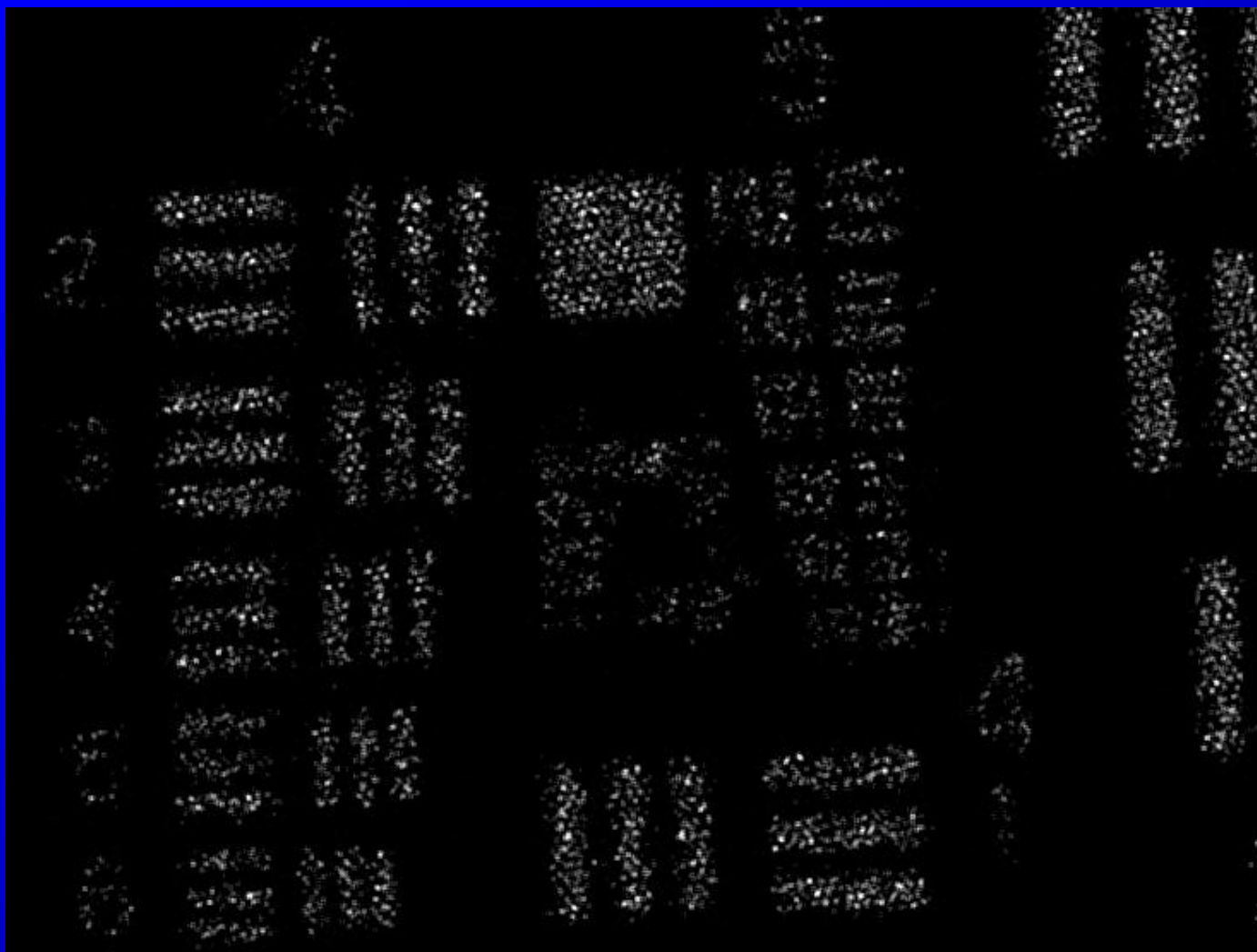

For better resolution see R. Bellazzini's poster 11.16



# Sub-pixel distortion

- There is a well understood distortion in the calculated centroid vs. the true centroid due to windowed sampling
  - Function of distribution size and sampling parameters
  - “Pulls” events towards center of 55  $\mu\text{m}$  pixel
  - Distortion repeats for every pixel
- If event sizes are uniform, it can be corrected by a histogram equalization technique and applied as a simple look-up table



# Modeled distortion for Gaussian

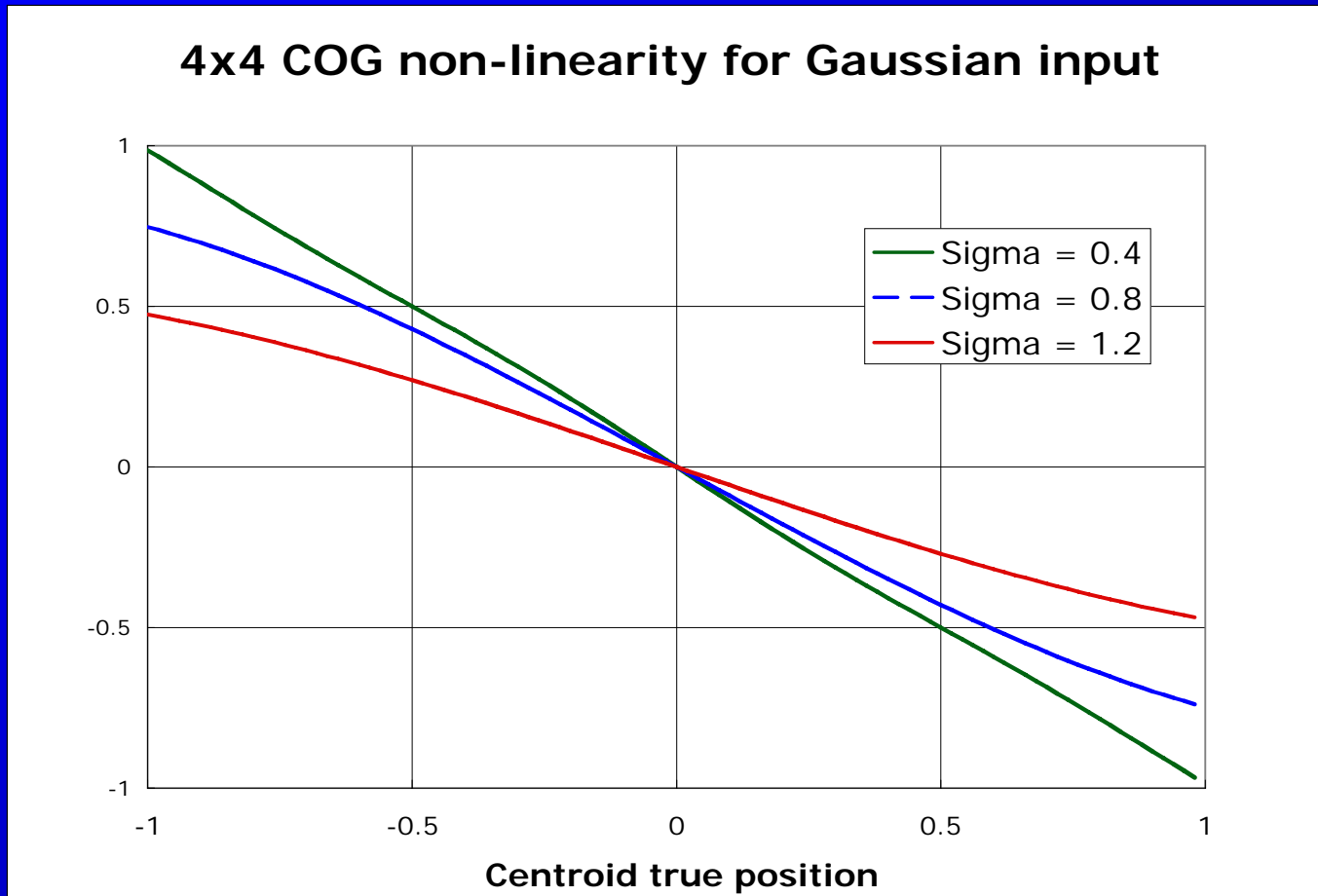

# Distortion (cont.)

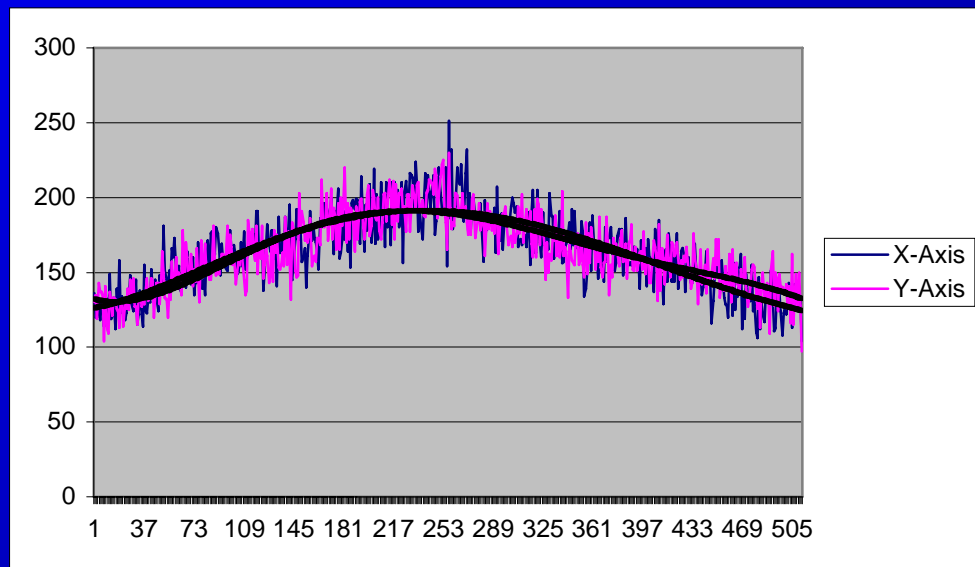
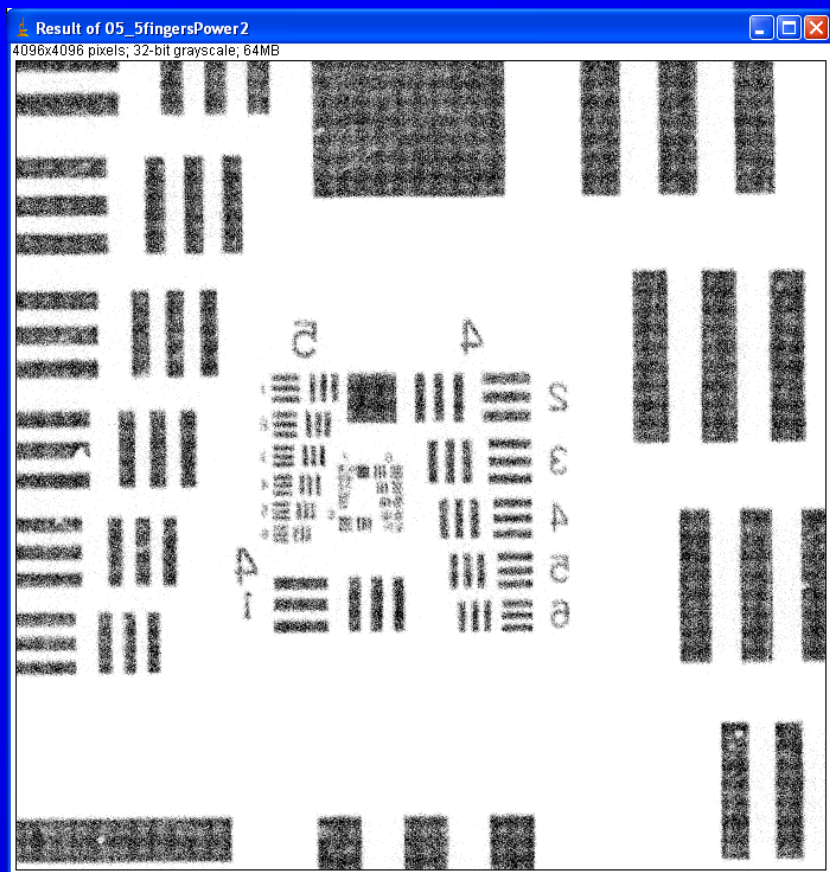

Distribution of sub-pixel locations  
across a single pixel

Use a histogram equalization  
technique to redistribute events  
uniformly across pixel



# Distortion corrected

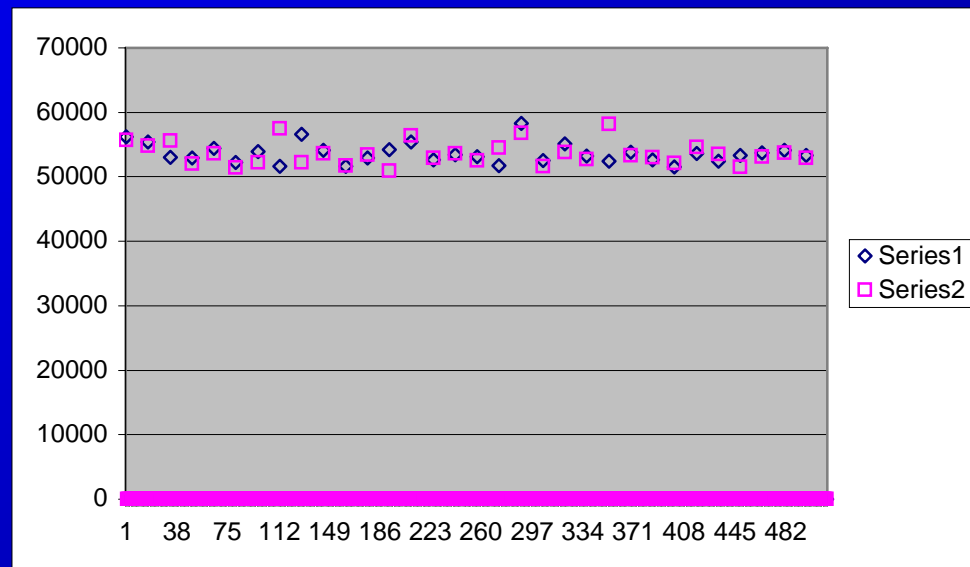
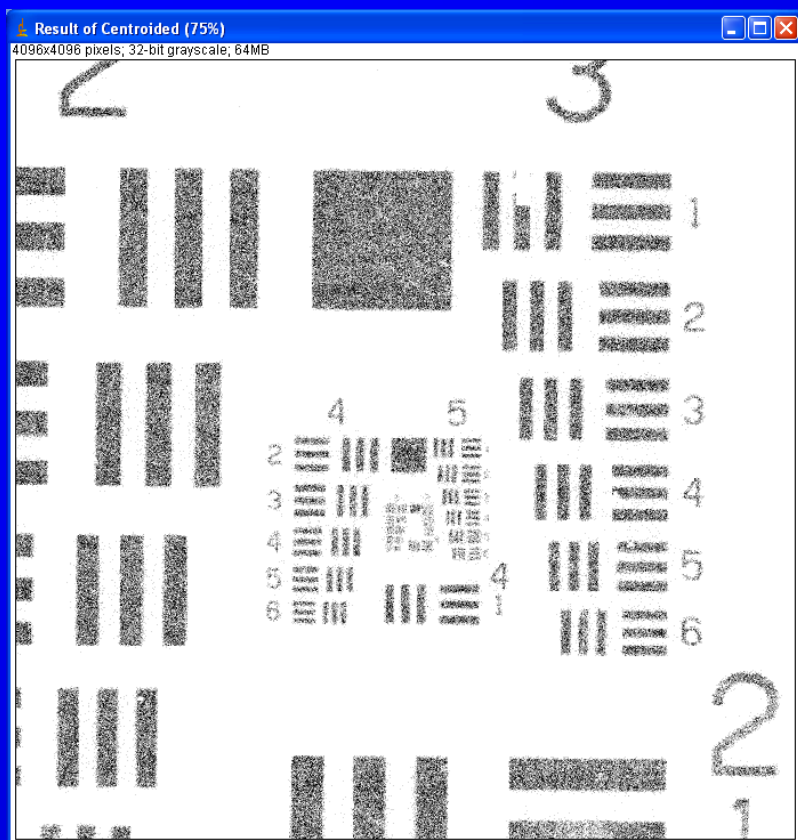

Distribution of corrected sub-pixel locations across a single pixel



# High resolution particle imaging

- This technique can improve particle imaging as long as the initial interaction length is smaller than a pixel and there is a mechanism to spread the collected charge to many pixels
  - Neutrons in  $^{10}\text{B}$  or Gd MCPs
  - Alphas in Si or MCPs
  - Electrons ( $< 50$  keV?) in MCPs
  - Soft x-rays in MCPs ( $< 10$  keV?)



# Neutron MCPs ( $^{10}\text{B}$ or Gd doped)

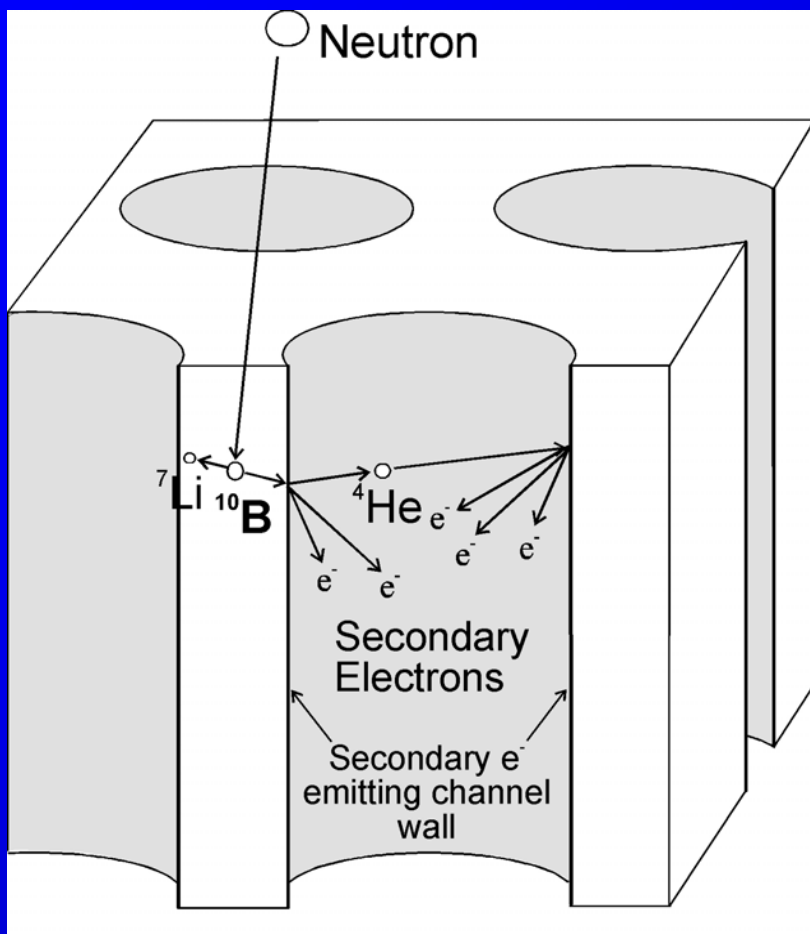

Absorption of Neutron

Secondary(s) reach surface of pore

Emission of photoelectron

Electron gain above electronic threshold

Similar to UV resolution

# Portable MCP vacuum housing

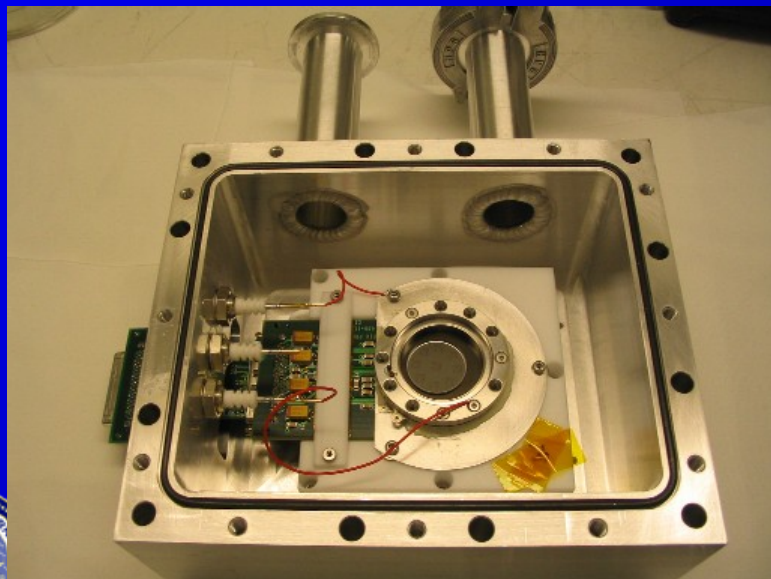
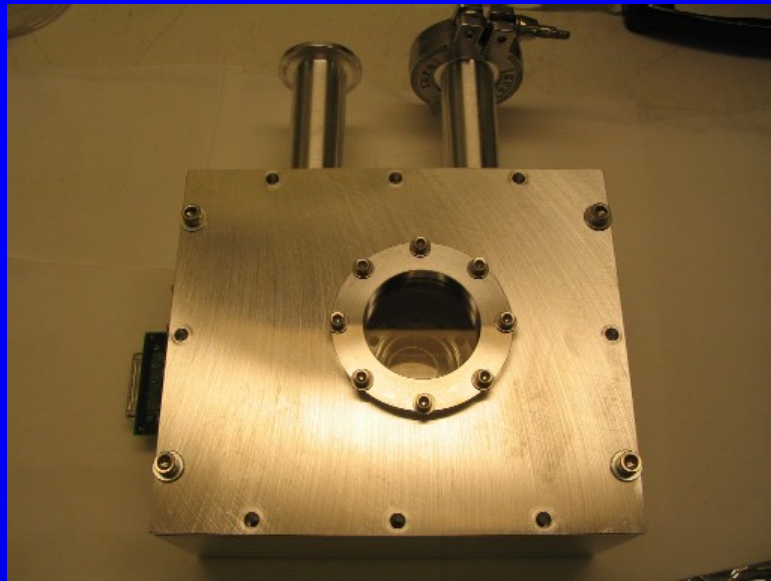

# Neutron detected with $^{10}\text{B}$ doped MCP

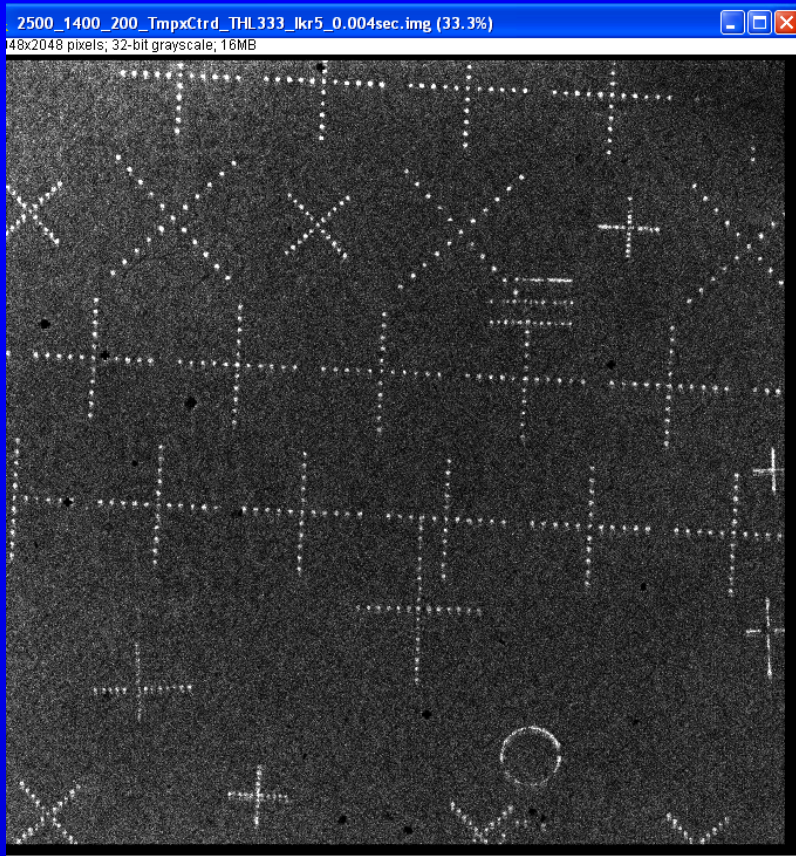

McClellan nuclear rad. facility

Thermal neutrons

Very high gamma bkgd.

Laser drilled Gd. mask



# Zoom - Neutron events

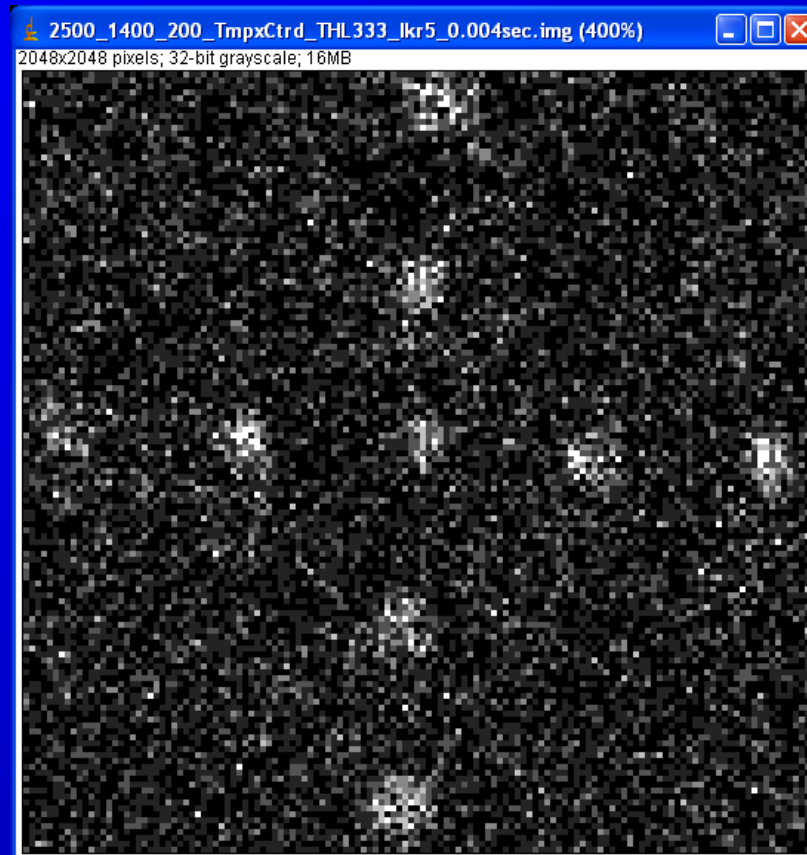

Holes approx. 60 microns



# Zoom - UV through same mask

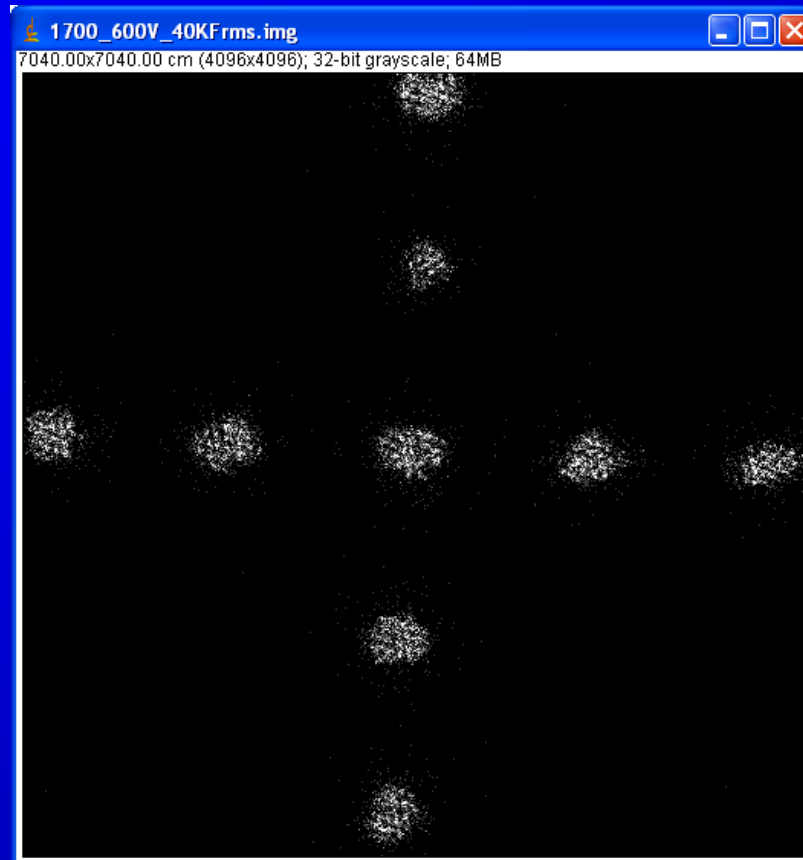

# Best resolution of neutrons

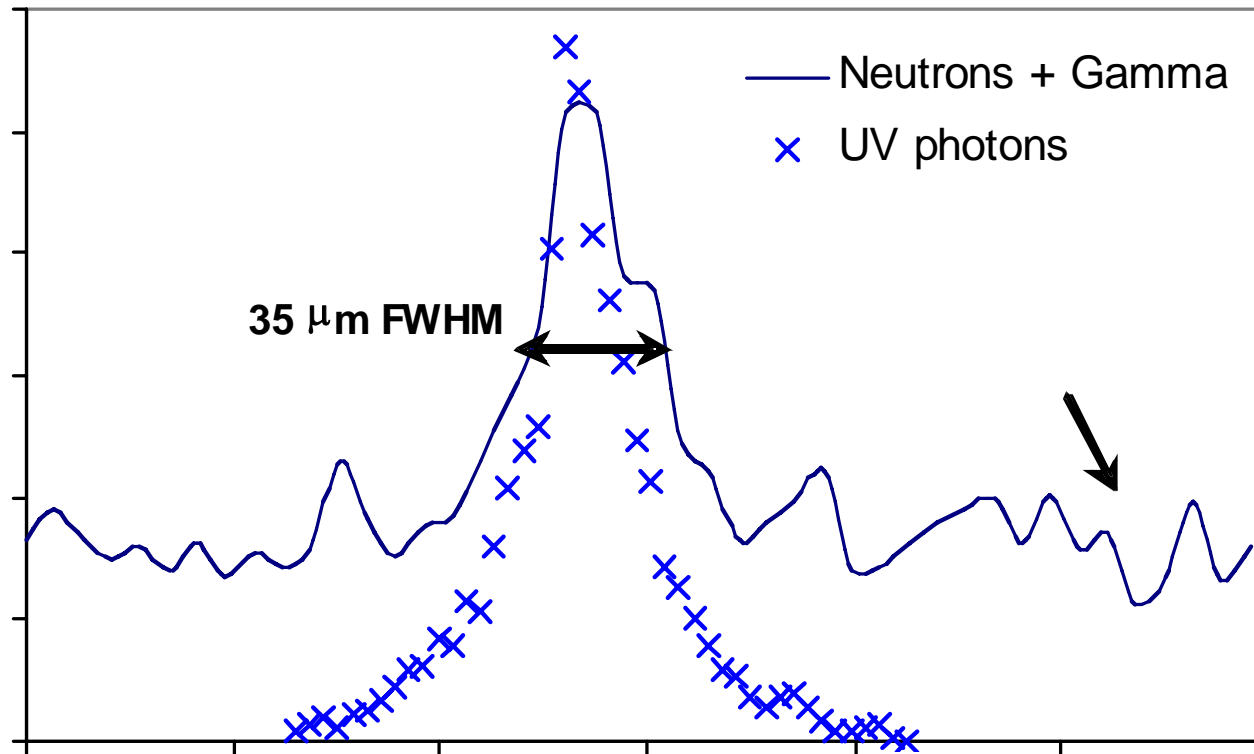

# Alpha imaging using Timepix/Si

Diffuse  $^{241}\text{Am}$

A schematic diagram of an alpha imaging setup. At the top, a red horizontal bar represents a source of diffuse  $^{241}\text{Am}$ . Four white arrows originate from this source and fan out downwards. Below the source is a thick orange horizontal layer labeled "Ni mask". The arrows pass through a narrow slit in the Ni mask. Below the mask is a large green area labeled "Si", representing a silicon detector. The arrows strike the top surface of a blue, semi-circular detector element within the Si region. At the bottom of the diagram, a purple horizontal layer contains several orange rectangular blocks, likely representing a substrate or support structure.

Ni mask

Si



# Centroiding large events with Silicon/Timepix

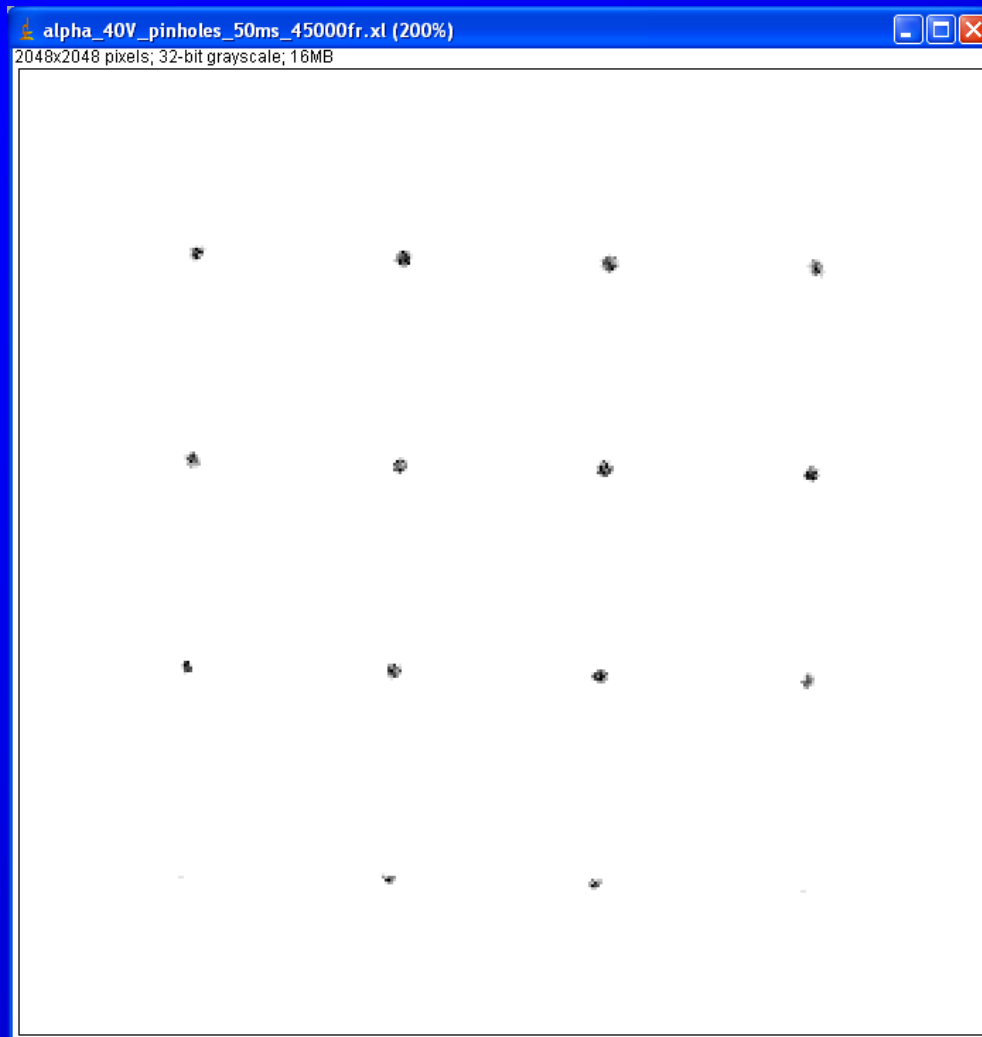

$^{241}\text{Am}$  Alphas (5MeV)  
through  $10\mu\text{m}$  holes on  
 $500\mu\text{m}$  centers

< 18 micron FWHM

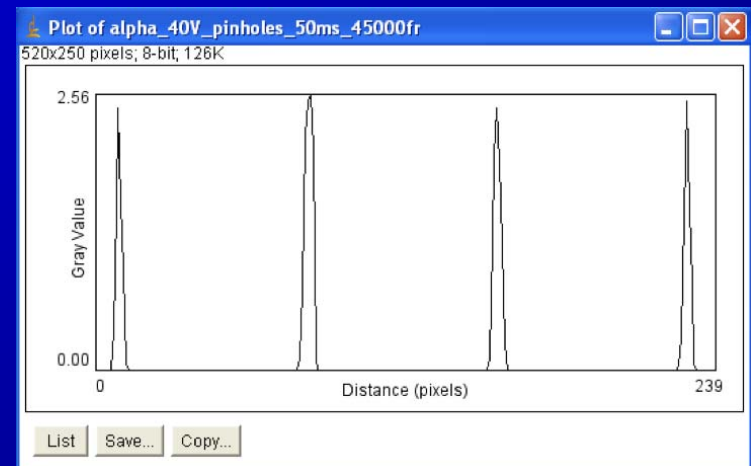

# Future work

- Integrate centroiding into PRIAM board (ESRF Grenoble) to get kHz framerates - factor of 50!
- Collision detection algorithm to reject miss-analyzed events
- Correct for pixel to pixel gain variations in TOT mode (necessary?)
- Optimize charge cloud size for resolution vs. rate



# Summary

- Timepix TOT mode allows us to improve spatial resolution of MCP readout by order of magnitude
- Very robust to variations of Timepix settings, nonlinearities, and non-uniformities
- Global ct. rate limited by event collision avoidance.
  - Counts/frame x Frames/sec  $\sim$  200 kHz
  - Local rate  $<$  10% of frame rate.  $\sim$  100 Hz
- Excellent for photon-starved astronomical applications (UV to x-ray)
- Biological Imaging? Neutron imaging? Electron imaging?



# Acknowledgements

This work was funded by an AODP grant managed by NOAO and funded by the NSF

The boron sensitive MCPs were loaned to us by Bruce Feller at Nova Scientific (Sturbridge Mass.)

We would also like to thank the Medipix2 Collaboration

